

# SAMPLE ROASTERS

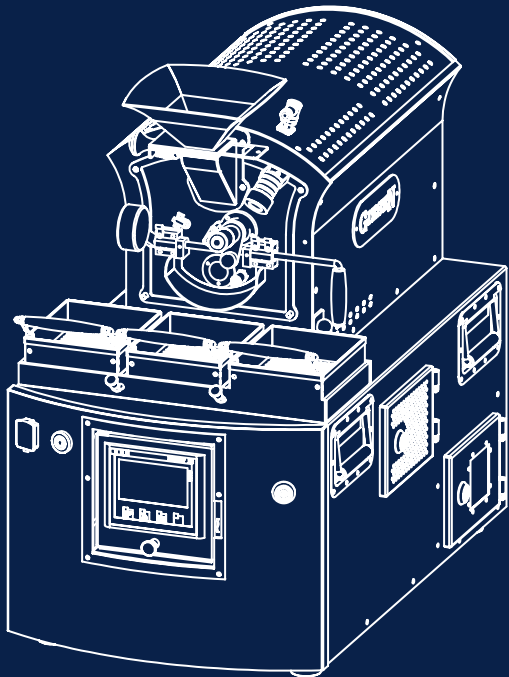

**GIESEN**<sup>®</sup>  
*coffee-roasters*

[info@giesencoffeeroasters.eu](mailto:info@giesencoffeeroasters.eu)



Industrieweg 13 -15  
7071CK Ulft  
The Netherlands



+31 (0)315 68 13 77

[www.giesencoffeeroasters.eu](http://www.giesencoffeeroasters.eu)

MANUFACTURER OF  
**HIGH QUALITY**  
COFFEE ROASTERS

**GIESEN**<sup>®</sup>  
*coffee-roasters*

# THE GIESEN STORY

With complete devotion, we aim to produce high quality coffee roasters that offer you the possibility to roast beans with more control than any other coffee roaster. By implementing new technology and focusing on developments in the industry, our team takes craftsmanship to the next level.

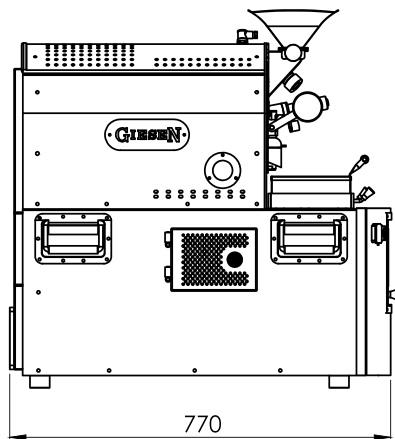
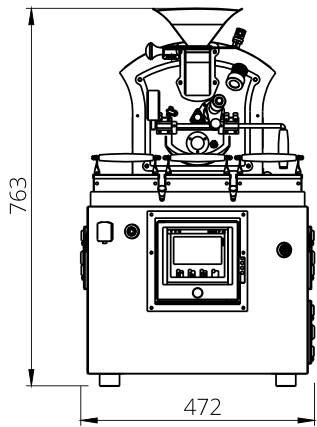

## WPE1 & WPG1



Experiment, test and compare with this sample roaster.

- » **COOLING TRAYS**  
Designed with three cooling trays it's the perfect roaster to compare three different samples side by side.
- » **CAPACITY**  
This roaster has a capacity of 50-200 gr. per batch.
- » **FUNCTIONALITIES**  
Control the entire roasting process, retrieve data and create roasting profiles.

### SPECIFICATIONS

 <b>Capacity</b> 50 - 200 gr.	 <b>Gastype</b> Natural & Propane (WPG1)	 <b>Weight</b> 85 kg	 <b>Heating</b> Electrical (WPE1)
 <b>Power</b> 230 V - 50/60 Hz	 <b>Exhaust</b> 80 mm	 <b>Certificates</b> CE	

### SAMPLE ROASTER

The WPG1 & WPE1 sample roaster enables you to find your perfect roast. It's the only sample roaster in the market that allows you to retrieve data and create a roasting profile. Designed with three cooling trays, it is possible to experiment, test and compare. By controlling drum speed, airtpeed and

temperature, you can control the entire roasting process. The industrial look and feel makes it the perfect model to place prominently in a store or bar. This sample roaster is available in two variations, the WPG1 gas roaster and the WPE1 electric roaster.

### WHAT OUR CLIENTS SAY ABOUT OUR WPG1/WPE1:

"Adding a roaster to your coffeeshop opens the door to creating your own brand of roasted coffee, attracting new customers, and furthering your 'coffee mission'." - Giesen Indonesia

### OPTIONS

- STANDARD BLACK/RVS
- STANDARD BLACK/CHROME
- UNPAINTED RAW LOOK
- POWDER COATED RAL/ROOF
- GOLD HAMMERED OR PAINTED ROOF
- ALL RAL COLORS
- COMPANY LOGO
- UNDER PRESSURE CONTROL
- ROAST PROFILE SOFTWARE
- ROAST PROFILE LAPTOP
- ROAST PROFILE TABLET
- CROPSTER ACCESS CODE
- REMOTE SUPPORT ROUTER
- TEMP. SENSOR DOUBLE READ OUT
- INFRARED SENSOR
- PRESENTATION TABLE