

W45A

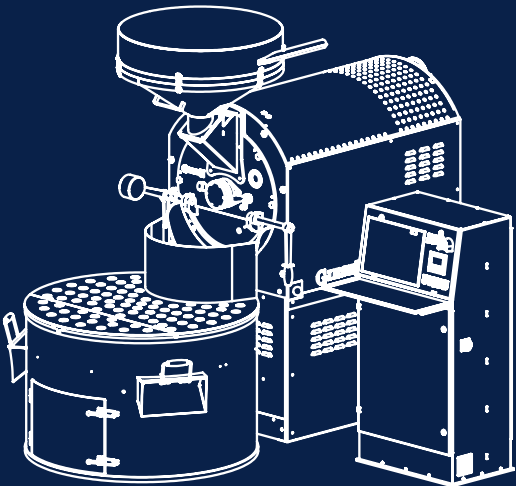

GIESEN[®]
coffee-roasters

info@giesencoffeeroasters.eu



Industrieweg 13 -15
7071CK Ulft
The Netherlands



+31 (0)315 68 13 77

www.giesencoffeeroasters.eu

MANUFACTURER OF
HIGH QUALITY
COFFEE ROASTERS

GIESEN[®]
coffee-roasters

THE GIESEN STORY

With complete devotion, we aim to produce high quality coffee roasters that offer you the possibility to roast beans with more control than any other coffee roaster. By implementing new technology and focusing on developments in the industry, our team take craftsmanship to the next level.

W45A

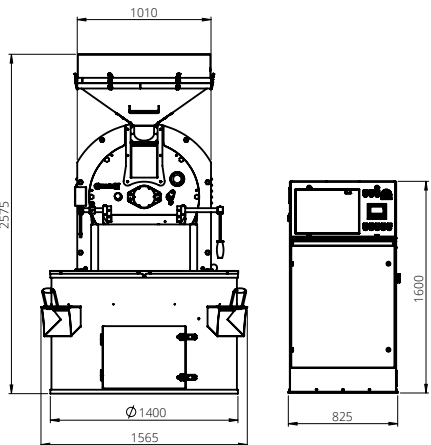

SPECIFICATIONS

 Capacity 22,5 - 45 kg	 Gastype Natural & Propane	 Weight 1800 kg
 Power 400 V - 50/60 Hz 3-phase	 Exhaust 2 x 200 mm	 Certificates CE

PRODUCTIVITY

The W45A coffee roaster can be operated completely automatically. The standard working steps are automated to ensure a fast, easy and efficient roasting process. With a green coffee conveyor, the green beans are being poured automatically into the hopper and will subsequently be released into the

roasting drum. After the roast, the roasted coffee beans will be poured into the cooling fan. This fan has a high cooling capacity of 3 minutes to cool down a whole batch of 45 kg coffee beans. At the same time, during the cooling phase, new green beans can be released into the drum for the next roast.

A complete solution for wholesale production

- » **BEAUTIFULLY ENGINEERED**
To ensure a fast, easy and efficient roasting process.
- » **ADVANCED TECHNOLOGY**
Plan, repeat and save your roasting profile with our built-in Roast Profile System. More options included. Free of charge.
- » **CAPACITY**
With a capacity of 45 kg per batch/ 180kg/h the roaster is well equipped for industrial purposes.

WHAT OUR CLIENTS SAY ABOUT OUR W45A:

"We decided to use a Giesen because the technology employed by their machines is always advancing. I am particularly happy with the shape of the drum, style and heat retention. The Giesen team is always happy to take feedback from industry professionals and apply newly developed technology in order to keep advancing and building better roasters.." - Sasa Sestic

INCLUDED:

- ROAST PROFILE TOUCH
- REMOTE SUPPORT ROUTER
- CYCLONE SLUICE

OPTIONS:

- STANDARD BLACK/RVS
- ALL RAL COLORS
- COMPANY LOGO
- BLACK POWDER COATED ROOF
- GOLD HAMMERED OR PAINTED ROOF
- COMPANY LOGO
- TEMP. SENSOR DOUBLE READ OUT
- INFRARED SENSOR
- CROPSTER ACCESS CODE
- DIGITAL BURNER ON HMI DISPLAY
- ONE SIDE AUTOMATIC COOL SIEVE

